

Edge AI Computer

RVS-D2F

Palm Size
145mm x 125 mm x 90.1 mm

MXM GPU
TYPE A : 82 x 70 mm



Fit Anywhere and Everywhere

-40°C ~ 60°C with GPU



RVS-D2F

Features

- ✓ 3x 2.5 GbE LAN
- ✓ 2x Displays (1x HDMI, 1x DP)
- ✓ 1x RS232/422/485, 1x RS232
- ✓ 6x USB (Support 4x USB3)
- ✓ 1x Mic In/Line Out
- ✓ 2x M.2 2242 M key (SATA III SSD) , support Raid 0/1
- ✓ 1x M.2 2242/3052 B key with SIM slot, support 4G/5G
- ✓ 1x Full Size Mini-PCIe with SIM slot, support 4G/5G
- ✓ 1x M.2 Key E Type 2230 for WIFI/BT/GPS
- ✓ 6~48V Wide DC In Voltage Input,
- ✓ Ignition Power Control
- ✓ Remote Control

SPECIFICATION

Product Name	RugCon-RVS-D2F
Generation	Intel® 13th/ 12th-Gen Core™ i9 / i7 /i5 (U_15W, P_28W, H_45W)
Memory	Max. Capacity : 64GB DDR5 with 2x SO-DIMM
Display	2x Display 1x Display Port, 4096*2304@60Hz 1x HDMI , 4096*2160@60Hz
LAN	3x 2.5 GbE
CAN	N//A
COM	1x RS232/422/485, 1x RS232
USB	6x USB (4x USB 3.2, 2x USB 2.0)
Audio	1x 3.5mm jack for Mic-In and Line-out
DIO	N//A
Storage	2x M.2 2242 M key (SATA III SSD) , Support Raid 0/1 , (1x M.2 2242 share with M.2 3052)
Internal Expansion	1x M.2 2242/3052 M-B key with SIM slot, support 4G/5G 1x Full Size Mini-PCIe with SIM slot, support 4G/5G 1x M.2 Key E Type 2230 for WIFI/BT/GPS
MXM Expansion	Support TYPE A : 82 x 70 mm MXM GPU Module
Mechanical	Dimension : 145(W) x 125(D) x85.6 (H) mm , Weight : 1.1 Kg , Mounting : Wall Mount
Temperature	Operating Temperature : -40° C ~ 70 °C (According to CPU) , TGP 65W (50 °C) , TGP 35W (60 °C) Storage Temperature : -40°C to 85°C
Humidity	Operating : 0~95%(non-condensing) Storage : 10~90%
Power	1x 3-pin pluggable terminal block for 6~48V DC Input 200V/1ms Surge Protection, Reverse-Voltage, Over-Voltage, Under-Voltage, Over-Current Protection 1x Power Button 1x 4-pin pluggable terminal block for Ignition/Remote power control
Vibration / Shock	Vibration test according to MIL-STD-810H, Method 514.8, Category 4 Shock test according to MIL-STD-810H, Method 516.8, Procedure I
EMC	CE/FCC Class A , according to EN 55032 & EN 55035 , (E-Mark / EN50155 / EN45545-2 by request)

Product Introduction

ENBIK's RugCon-**RVS-D2F** is the **world's smallest** MXM GPU edge AI computer which has ultra-mini size with only 145 x 125 x 90 mm ideal to operate effectively in space-constrained and wide operating temperature environments, In addition, because RVS-D1F has a bilateral heat dissipation design, it can easily perform AI tasks in the edge high-temperature environment. **Because RVS-D2F adopts a low-power Intel high-performance processor and GPU, it can easily work in an edge environment with limited power supply and show excellent AI reasoning tasks.** RVS-D2F offers a wide range of I/O ports including 3x 2.5GbE, 1x RS232/422/485, 1x RS232, 6x USB and Multiple M.2 internal expansion slots for 5G/4G/WIFI/GPS. RVS-D2F also has 2x M.2 2242 SATA III slots, which can install two SSD at the same time.

What is exciting is that the **RVS-D2F** can support MXM GPU of NVIDIA, which is only the size of a palm, can actually support **NVIDIA RTX4070/RTX4060/RTX4050/RTX2000/A2000**, and the maximum computing power can reach 321TOPS, which undoubtedly makes software developers more excited. The rich NVIDIA software ecosystem makes edge artificial intelligence deployment faster and easier to implement, effectively solves the installation and low-latency reasoning problems of various artificial intelligence models at the edge, and quickly makes various decisions and judgments at the edge. Modular GPU scalability ensures seamless upgrades to meet evolving application demands, the ENBIK's **RVS-D2F** is definitely the best choice for edge deployment of demanding artificial intelligence tasks, limited space and limited power supply in various edge applications.

Product Application

ENBIK RugCon-**RVS-D2F** is suitable for edge computing, AIoT, machine vision, AGV/AMR, In-Vehicle systems, rail transit, robot control and automation control, as well as various harsh and extreme edge environments with limited installation space and limited power supply.

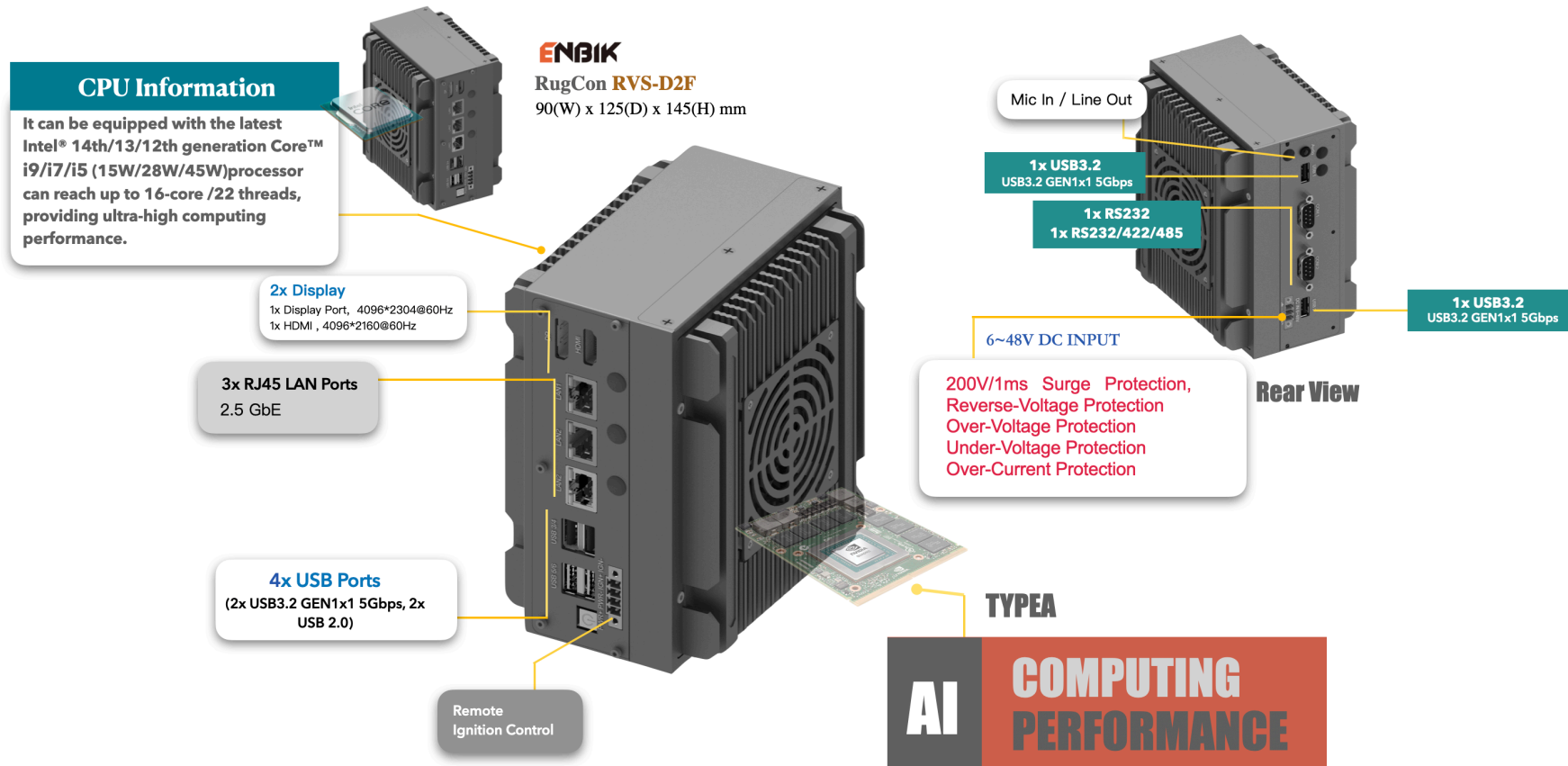

System Dimension : Compact Size : 145 mm x 125 mm x 90.1 mm

1. With Wall Mount Kit Dimension : 177 mm x 125 mm x 106.2 mm

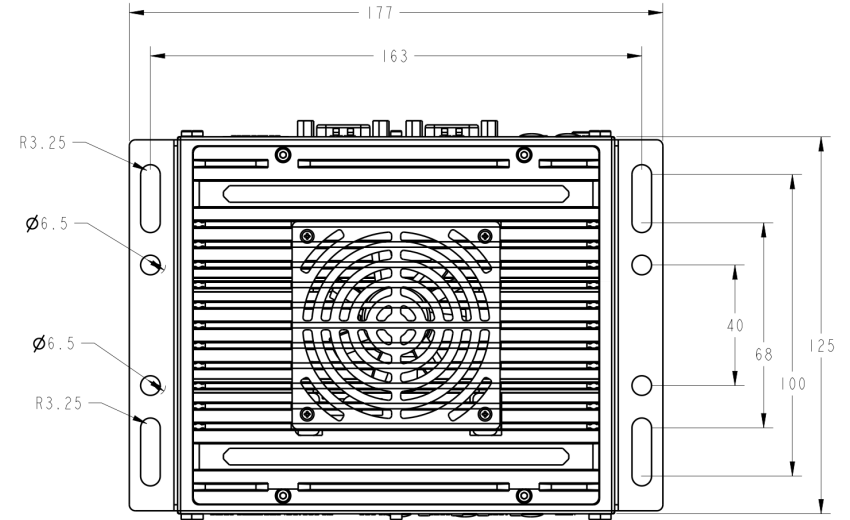
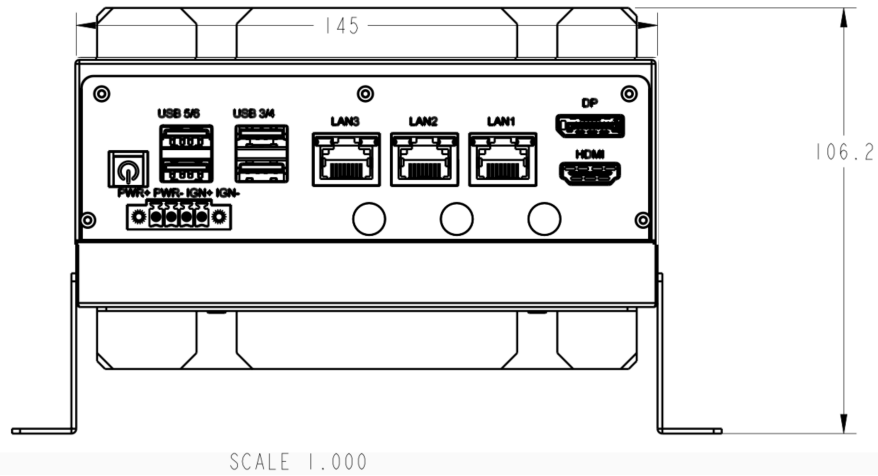

2. With Stand Kit Dimension : 123.1 mm x 150.5 mm x 125 mm

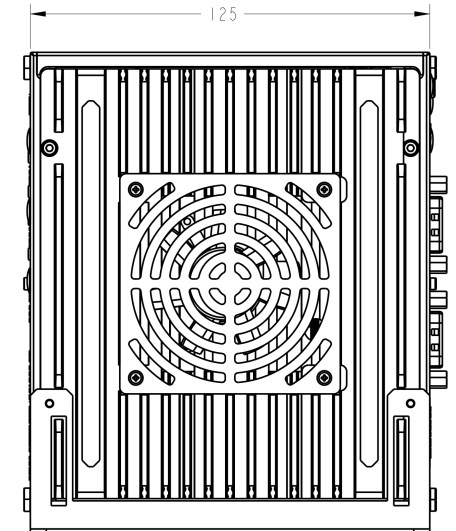
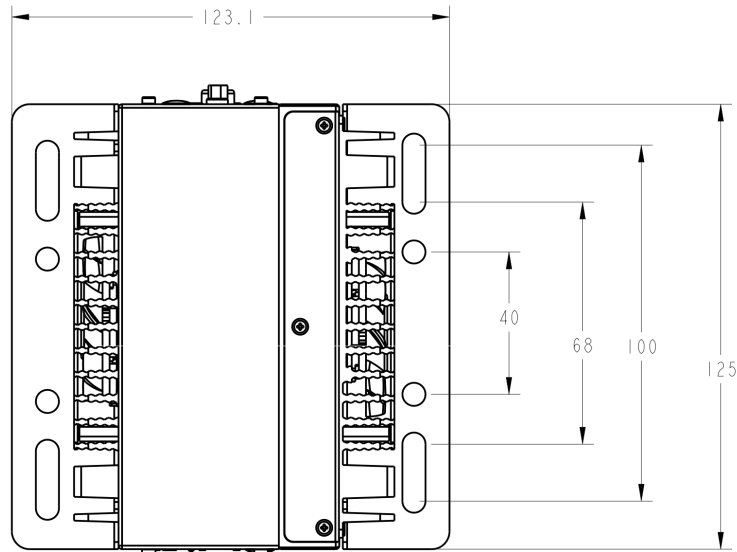
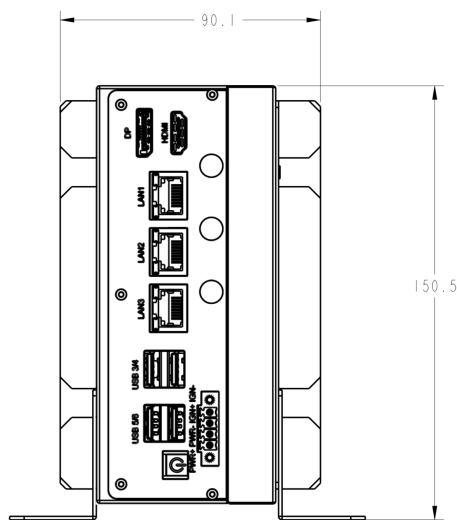

12th Gen Intel® Core™ mobile processors (formerly Alder Lake-P)

CPU Module	Description
i9-12900H	Intel® Core™ i9-12900H processor with 6 P-cores and 8 E-cores up to 5.0GHz 24MB Intel® Smart Cache Intel® Iris® Xe Graphics architecture with 96 EUs Intel® code name Alder Lake-P (H-Series,45W)
i7-12700H	Intel® Core™ i7-12700H processor with 6 P-cores and 8 E-cores up to 4.7GHz 24MB Intel® Smart Cache Intel® Iris® Xe Graphics architecture with 96 EUs Intel® code name Alder Lake-P (H-Series,45W)
i5-12600H	Intel® Core™ i5-12600H processor with 4 P-cores and 8 E-cores up to 4.5GHz 18MB Intel® Smart Cache Intel® Iris® Xe Graphics architecture with 80 EUs Intel® code name Alder Lake-P (H-Series,45W)
i7-1260P	Intel® Core™ i7-1260P processor with 4 P-cores and 8 E-cores up to 4.7GHz 18MB Intel® Smart Cache Intel® Iris® Xe Graphics architecture with 96 EUs Intel® code name Alder Lake-P (P-Series,28W)
i5-1250P	Intel® Core™ i5-1250P processor with 4 P-cores and 8 E-cores up to 4.4GHz 12MB Intel® Smart Cache Intel® Iris® Xe Graphics architecture with 80 EUs Intel® code name Alder Lake-P (P-Series,28W)
i5-1235U	Intel® Core™ i5-1235U processor with 2 P-cores and 8 E-cores up to 4.4GHz 12MB Intel® Smart Cache Intel® Iris® Xe Graphics architecture with 80 EUs Intel® code name Alder Lake-P (U-Series,15W)
i3-1215U	Intel® Core™ i3-1215U processor with 2 P-cores and 4 E-cores up to 4.4GHz 10MB Intel® Smart Cache Intel® UHD Graphics 64EU Intel® code name Alder Lake-P (U-Series,15W)

13th Gen Intel® Core™ mobile processors (formerly Raptor Lake-P)

CPU Module	Description
i9-13900HK	Intel® Core™ i9-13900HK processor with 6 P-cores and 8 E-cores up to 5.4GHz 24MB Intel® Smart Cache Intel® Iris® Xe Graphics architecture with 96 EUs Intel® code name Raptor Lake-P (H-Series,45W)
i7-13800H	Intel® Core™ i7-13800H processor with 6 P-cores and 8 E-cores up to 5.2GHz 24MB Intel® Smart Cache Intel® Iris® Xe Graphics architecture with 96 EUs Intel® code name Raptor Lake-P (H-Series,45W)
i5-13600H	Intel® Core™ i5-13600H processor with 4 P-cores and 8 E-cores up to 4.8GHz 18MB Intel® Smart Cache Intel® Iris® Xe Graphics architecture with 80 EUs Intel® code name Raptor Lake-P (H-Series,45W)
i7-1360P	Intel® Core™ i7-1360P processor with 4 P-cores and 8 E-cores up to 5.0GHz 18MB Intel® Smart Cache Intel® Iris® Xe Graphics architecture with 96 EUs Intel® code name Raptor Lake-P (P-Series,28W)
i5-1350P	Intel® Core™ i5-1350P processor with 4 P-cores and 8 E-cores up to 4.7GHz 12MB Intel® Smart Cache Intel® Iris® Xe Graphics architecture with 80 EUs Intel® code name Raptor Lake-P (P-Series,28W)
i5-1335U	Intel® Core™ i5-1335U processor with 2 P-cores and 8 E-cores up to 4.6GHz 12MB Intel® Smart Cache Intel® Iris® Xe Graphics architecture with 80 EUs Intel® code name Raptor Lake-P (U-Series,15W)
i3-1315U	Intel® Core™ i3-1315U processor with 2 P-cores and 4 E-cores up to 4.5GHz 10MB Intel® Smart Cache Intel® UHD Graphics 64EU Intel® code name Raptor Lake-P (U-Series,15W)

Note 1 : Embedded or other Processors also be supported , please contact our sales channel .

Select the power of artificial intelligence

AI Chip	GeForce RTX Series			QUADRO EMBEDDED	
	RTX4070-8G	RTX4060-8G	RTX4050-6G	RTX2000-8G	A2000-8G
Generation	Ada Generation	Ada Generation	Ada Generation	Ada Generation	Ampere
Chip Clock	735MHz (Boost 1230MHz)	1140MHz (Boost 1470MHz)	1140MHz (Boost 1605MHz)	1635MHz(Boost 2115MHz)	1087MHz(Boost 1552MHz)
Memory	8GB GDDR6 128bit	8GB GDDR6 128bit	6GB GDDR6 96bit	GDDR6 8GB 128bit	GDDR6 8 GB 128bit
Memory Clock	2000 MHz	2000 MHz	2000 MHz	1250 MHz	1375 MHz
Memory Bandwidth	256.0 GB/s	256.0 GB/s	192.0 GB/s	256.0 GB/s	176.0 GB/s
Single Precision	15.71 TFLOPS	12.22 TFLOPS	8.218 TFLOPS	14.176 TFLOPS	8.958 TFLOPS
TOPS	321	232	194	232	-
CUDA	4608	3072	2560	3072	2560
Tensor Core	144	96	80	96	80
RT core	36	24	20	24	20
TGP	65W	60W	35W	56.5W	38W/50W
Dimension	TYPE A : 82 x 70 mm	TYPE A : 82 x 70 mm	TYPE A : 82 x 70 mm	TYPE A : 82 x 70 mm	TYPE A : 82 x 70 mm

Note 2 : Embedded or other MXM GPU Module also be supported , please contact our sales channel .